

# Toxic Gas Sensor Operating Instructions

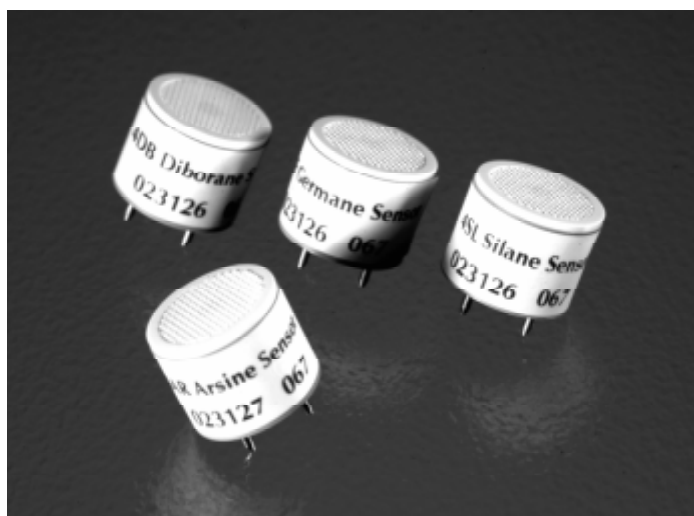

## Contents

Introduction .....	TOX-2
Reaction Mechanisms .....	TOX-3
Selectivity .....	TOX-5
Safety Monitoring .....	TOX-5
Health & Safety Executive Exposure Levels .....	TOX-6
Circuitry .....	TOX-7
a) Three electrode CiTicels .....	TOX-7
1) Standard Operation ('Unbiased') .....	TOX-7
2) 'Biased' Operation .....	TOX-8
b) Four electrode CiTicels .....	TOX-9
Operation .....	TOX-10
Start Up .....	TOX-10
Sampling Systems .....	TOX-10
Calibration .....	TOX-11
Cross Sensitivity Data .....	TOX-12
In-Board Filters .....	TOX-14
Pressure Effects .....	TOX-14
Temperature Dependence .....	TOX-15
Humidity Effects .....	TOX-16

**CiTicels®**

# Toxic Gas CiTiceLs

## Introduction

The Toxic Gas CiTiceL development programme began in 1981 with the introduction of the Carbon Monoxide CiTiceL. Since then new CiTiceLs have been developed for various toxic gases, most recently ozone and ethylene oxide, resulting in a range of sensors with an enviable reputation for reliability, stability and robust design.

These sensors are micro fuel cells, designed to be maintenance-free and stable for long periods. They use the technology that was pioneered with the original Oxygen CiTiceL, which results in a direct response to volume concentration rather than partial pressure.

The central feature of the design is the gaseous diffusion barrier, which limits the flow of gas to the *Sensing* electrode. The electrode is therefore able to react all target gas as it reaches its surface, and still has electrochemical activity in reserve. This high activity reserve ensures each CiTiceL has a long life and excellent temperature stability.

### Two electrode CiTiceLs

The simplest form of sensor operating on electrochemical principles has two electrodes - *Sensing* and *Counter* - separated by a thin layer of electrolyte and connected by a low resistance external circuit. Gas diffusing into the sensor is reacted at the surface of the *Sensing* electrode, by oxidation or reduction, causing a current to flow between the electrodes through the external circuit. The current is proportional to the concentration of gas and can be measured across a load resistor in the external circuit.

For reaction to take place the *Sensing* electrode potential must be within a specific range. As the gas concentration increases so does the current flow, causing a change in the potential of the *Counter* electrode (polarisation). With the electrodes connected together by a simple load resistor, the *Sensing* electrode potential follows that of the *Counter*. If the gas concentration continues to rise, the *Sensing* electrode potential will eventually move outside its permitted range. At this point the sensor will become non-linear, effectively limiting the upper concentration of gas a two electrode sensor can be used to measure.

**Figure tox1**  
Toxic Gas CiTiceL  
schematic drawing

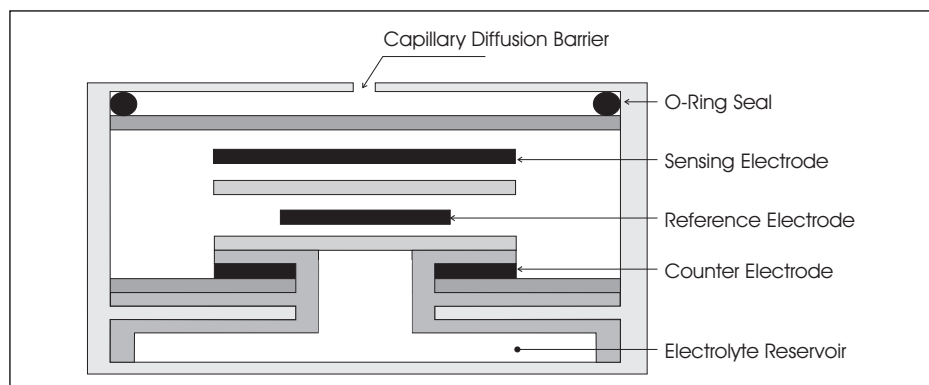



### Three electrode CiTiceLs

The limitation imposed by *Counter* electrode polarisation can be avoided by introducing a third, *Reference* electrode, and using an external potentiostatic operating circuit. With this arrangement the *Sensing* electrode is held at a fixed potential relative to the *Reference* electrode. No current is drawn from the *Reference* electrode, so both maintain a constant potential. The *Counter* electrode is still free to polarise, but this has no effect on the *Sensing* electrode and so does not limit the sensor in any way. Consequently the range of concentrations a three electrode sensor can be used to measure is much greater.

All 4-Series CiTiceLs (except the 4COSH) have a three electrode design. By controlling the potential of the *Sensing* electrode, the potentiostatic circuit also allows greater selectivity and improved response to the target gas. The same circuit is used to measure the current flow between the *Sensing* and *Counter* electrodes. It can be a very small, low power device, and recommended circuits are given later in this chapter.

### Four electrode CiTiceLs

Further development of the three electrode design has led to development of four-electrodes sensors, one of which is the 4COSH CiTiceL.

The 4COSH has an additional sensing electrode, allowing it to detect two gases (CO and H<sub>2</sub>S) simultaneously. The two sensing electrodes provide distinct output signals for the two different gases.

## Reaction Mechanisms

Gas diffusing into a CiTiceL is reacted at the *Sensing* electrode by oxidation (most gases) or reduction (e.g. nitrogen dioxide and chlorine). Each reaction can be represented in standard chemical equation form. The oxidation of carbon monoxide, for example, at the *Sensing* electrode can be represented by the equation:-



A similar equation can be derived for other CiTiceLs, depending on the reaction of the target gas on the *Sensing* electrode:-

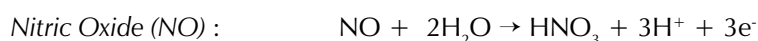
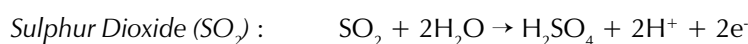
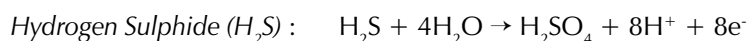

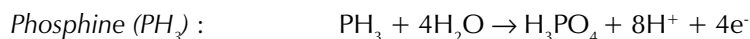
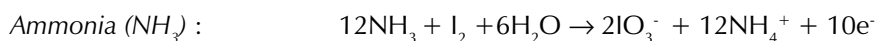
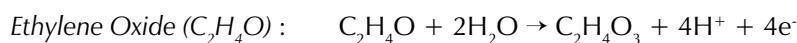

The *Counter* electrode acts to balance out the reaction at the *Sensing* electrode. If oxidation occurs at the *Sensing* electrode, oxygen will be reduced to form water at the *Counter*. If, however, the *Sensing* electrode reaction is a reduction, the *Counter* electrode reaction will be reversed (i.e. water will be oxidised). The standard equation for this electrode can be written as:-

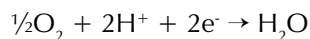

The equations for the two electrodes can be combined and simplified to give an overall cell reaction. In the case of carbon monoxide, for example, this can be written as:-

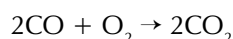

This overall equation demonstrates that the fuel for the reactions are gases supplied to the sensor, and the product is a gas emitted. In other words the sensor is merely a catalyst for the reaction, and no part of it is directly consumed (Note: except in the case of the Ammonia and Hydrogen Cyanide CiTiceLs - see below).

**Note:** Ammonia and Hydrogen Cyanide CiTiceLs employ a novel electrolyte, in which the reaction mechanism is not straightforward oxidation or reduction as used in other sensors. This has important consequences on their performance, especially on output drift and operating life. The sensors are therefore suitable for leak detection, but not applications where high concentrations or continuous exposures are likely. The specifications quoted in the data sheets assume the total monthly exposure does not exceed a specified level.



---

## Selectivity

---

CiTiceLs are designed to be highly specific to the gas they are intended to measure, and the effect from other cross-interfering gases has been minimised. This is largely achieved by a combination of the following techniques:-

**1) Development of specific electrode catalysts.**

The choice of electrode material has a strong influence on the gas a sensor will react. Each of the reactions shown on page TOX-3 is catalysed by an electrode material specially developed by City Technology.

**2) Control of operating potential of the sensing electrode.**

A major advantage of the three-electrode design is it allows a 'bias' voltage to be applied to the sensor, thus enabling the oxidation or reduction of less electrochemically reactive gases. The appliance of such a bias promotes reactions which would not normally occur at the *Reference* electrode potential.

**3) Use of chemical filters to remove interfering gases selectively.**

Some sensors have inboard filters to remove gases that would otherwise react on the *Sensing* electrode. The filters vary in composition and size depending on the exposure a sensor is likely to have in its intended application. More details are given later in this chapter.

---

## Safety Monitoring

---

For applications concerned with personnel safety, an instrument is required to signal when the Short-Term Exposure (STEL) and the Long-Term Exposure (TWA) limits are reached. The table on page TOX-6 shows the current exposure limits for the main gases CiTiceLs are used to monitor. This table is for guidance only, and figures must be checked before being used. Sensors used in safety applications should be fully calibrated at least every six months. However as safety is of paramount importance, a check that the sensor is working should be carried out on a more regular basis (e.g. fortnightly). Calibration details are given on page TOX-11.



## Health & Safety Executive Exposure Levels

GAS	U.K. <sup>(1)</sup>		GERMANY <sup>(2)</sup>		USA <sup>(3)</sup>	
	STEL (10 min)	TWA (8 hr)	STEL <sup>(4)</sup>	TWA (8 hr)	STEL (15 min)	TWA (8 hr)
CO	300	50	60 (30)	30	200	35
H <sub>2</sub> S	15	10	20 (10)	10	15	10
SO <sub>2</sub>	5	2	4 (5)	2	5	2
NO	35	25	-	-	-	25
NO <sub>2</sub>	5	3	10 (5)	5	1	3
Cl <sub>2</sub>	1	0.5	1 (5)	0.5	1	0.5
ClO <sub>2</sub>	0.3	0.1	0.2 (5)	0.1	0.3	0.1
H <sub>2</sub> <sup>(5)</sup>	-	-	-	-	-	-
HCN	10	-	20 (30)	10	4.7	-
HCl	5	-	10 (5)	5	5	-
NH <sub>3</sub>	35	25	100 (5)	50	35	25
O <sub>3</sub>	0.2	-	0.2 (5)	0.1	0.1	-
C <sub>2</sub> H <sub>4</sub> O	-	5	-	-	5	1
PH <sub>3</sub>	0.3	-	0.2 (5)	0.1	1	0.3

<sup>(1)</sup> Source: Health and Safety Executive (HSE) - EH40/97

<sup>(2)</sup> Source: Deutsche Forschungsgemeinschaft (DFG) - 1993

<sup>(3)</sup> Source: Occupational Safety and Health Administration (OSHA) - Code of Federal Regulations 29 CFR 1910.1000-1910.1200, July 1993

<sup>(4)</sup> Figures in brackets represent maximum duration, in minutes, of exposure at this level.

<sup>(5)</sup> Hydrogen is a flammable asphyxiant. The LEL value is 4%



# Toxic Gas CiTiceL Operation

## Circuitry

### a) Three electrode CiTiceLs

#### 1) Standard Operation ('Unbiased')

Figure TOX3 shows the recommended circuit for use with any three electrode CiTiceL designed to measure the following gases:- carbon monoxide (CO), hydrogen sulphide (H<sub>2</sub>S), sulphur dioxide (SO<sub>2</sub>), nitrogen dioxide (NO<sub>2</sub>), chlorine (Cl<sub>2</sub>), hydrogen (H<sub>2</sub>), and hydrogen cyanide (HCN). The output from the circuit will be **Positive** with respect to common for gases that are oxidised at the *Sensing* electrode - CO, H<sub>2</sub>S, SO<sub>2</sub>, H<sub>2</sub>, PH<sub>3</sub>, HCN and SiH<sub>4</sub> and **Negative** with respect to common for gases which are reduced at the *Sensing* electrode - NO<sub>2</sub> and Cl<sub>2</sub>. All other CiTiceLs require biased operation for which a modification to the standard circuit is required (see page TOX-8).

The function of the *Counter* electrode is to complete the electrochemical circuit and its potential relative to the *Sensing* and *Reference* electrodes is not fixed by the circuit. Under quiescent conditions, the cell is drawing a very small current and the *Counter* electrode will be near its rest potential. When gas is detected, the cell current rises and the *Counter* electrode polarises with respect to the *Reference* electrode (negative for CO, H<sub>2</sub>S, SO<sub>2</sub>, H<sub>2</sub>, HCN, PH<sub>3</sub>, HCN, and SiH<sub>4</sub> - positive for NO<sub>2</sub> and Cl<sub>2</sub>).

While the cell current stabilises very quickly, the *Counter* electrode polarises slowly and may continue to drift even though the sensor signal is stable. This is normal, and in practice the maximum *Counter* electrode polarisation likely is 300-400mV with respect to the *Reference* electrode. In practical terms this means the circuit ground should be derived at a higher value than the negative supply rail (e.g. 1V), so that IC1 can give a negative output.

\*It is important, on switch on, that IC1 has a low offset (e.g. <100μV), or the op amp will effectively bias the sensor. The sensor will then take a correspondingly long time to settle down from the shorted condition.

The voltage developed across R<sub>Load</sub> should be restricted to less than 10mV under all conditions otherwise sensor performance will suffer. Keeping R<sub>Load</sub> low also ensures a faster response time, and although in this circuit it can be reduced to zero, a small finite value is recommended. This ensures a better balance between circuit noise and response time, and in some cases reduces the humidity transient (see page TOX-16).

To maintain a CiTiceL in a 'ready to work' state when an instrument is switched off, the *Reference* and *Sensing* electrodes must be shorted together. This is done by shorting the *Reference* to the circuit common with an FET, as in figure TOX3, or using a ganged on/off switch. While shorted it is important to avoid exposure to active gases or solvent vapours.

**Figure TOX3**

 Three electrode CiTiceL:  
Standard operating circuit

\***IC1** - This amplifier should have either a low offset or have its offset nulled out. The PMI OP-77 and OP-90 and Linear Technology LT1078 are all suitable.

**IC2** - This amplifier acts as a current to voltage converter and its offset performance is less critical. The OP-77 or similar is a suitable choice

Recommended values of  $R_{load}$  are given in Part I.

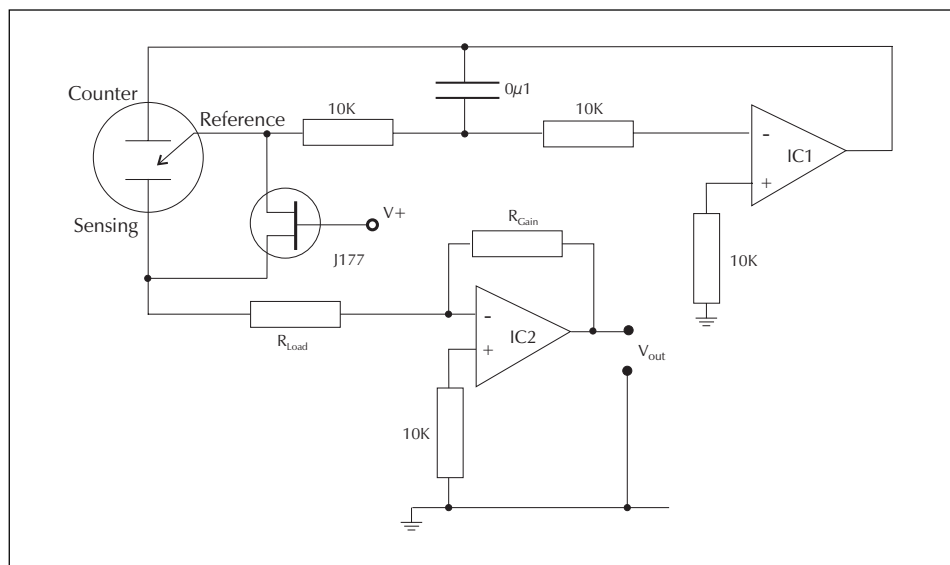

## 2) 'Biased' Operation

CiTiceLs for measuring nitric oxide (NO), ethylene oxide (C<sub>2</sub>H<sub>4</sub>O), and ammonia (NH<sub>3</sub>) are designed to work with the *Sensing* electrode at a more positive potential than the *Reference* electrode. This is known as '**biased**' operation, and the recommended operating circuit is shown on page TOX-9.

The recommended biased operation circuit is basically the same as in figure TOX3. It is modified, however, such that the positive input of IC1 is at the required potential below the circuit common, and this provides the bias voltage. As all the sensors requiring biased operation measure gases oxidised at the *Sensing* electrode, the output from the circuit will always be **Positive** with respect to common.

The bias voltage must be applied via IC1 so as not to draw any current from the *Reference* electrode. It must not be applied by connecting a battery directly to the *Reference* and *Sensing* electrodes. It is strongly recommended that a bias potential is maintained at all times, even when an instrument is switched off. **If it is not maintained, very long start up times will be required when the instrument is switched on.** Applying bias to a new CiTiceL will produce a large, rapidly decreasing baseline which is sufficiently stable after several hours for measurements to be made (two to three hours for the ammonia and nitric oxide sensors, 24 hours or longer for hydrogen chloride). The baseline will continue to stabilise slowly during the following three weeks, after which time it should be fully settled.

The recommended bias voltage for each CiTiceL is given in the relevant specifications in Part I. In each case the recommended level has been shown to offer the greatest balance of features for operational use. A positive bias voltage indicates the *Sensing* electrode will be more positive than the *Reference* electrode.

**Caution:** The *Reference* and *Sensing* electrodes of CiTiceLs requiring biased operation are not meant to have the same potential, so are despatched from City Technology without the usual shorting link. As shorting can cause permanent damage, these CiTiceLs must be stored with the electrodes unshorted. For this reason the shorting FET used in the unbiased circuit is omitted in the recommended bias circuit.





**Figure tox4**  
Three electrode CiTiceL:  
Biased mode operating  
circuit

**IC1** - As above.  
**IC2** - As above.  
 $V_{ref}$  is a precision bandgap voltage reference. The Teledyne TC04 series is recommended.  
Recommended values of  $R_{load}$  are given in Part I.

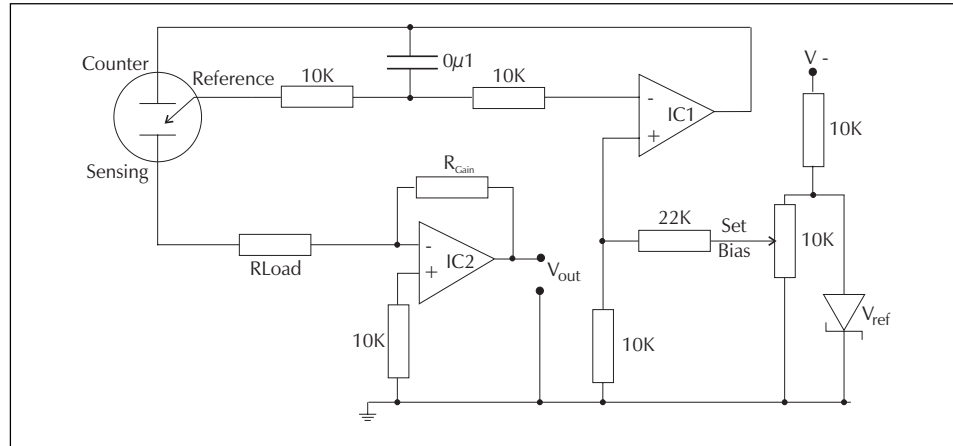

**b) Four electrode CiTiceLs**

**Figure tox5**  
Four electrode CiTiceL:  
Standard Operating Circuit

**IC1** - This amplifier should have either a low offset or have its offset nulled out. The PMI OP-77 and OP-90 and Linear Technology LT1078 are all suitable.  
**IC2, IC3** - This amplifier acts as a current to voltage converter and its offset performance is less critical. The OP-77 or similar is a suitable choice  
Recommended values of  $R_{load}$  are given in Part I.

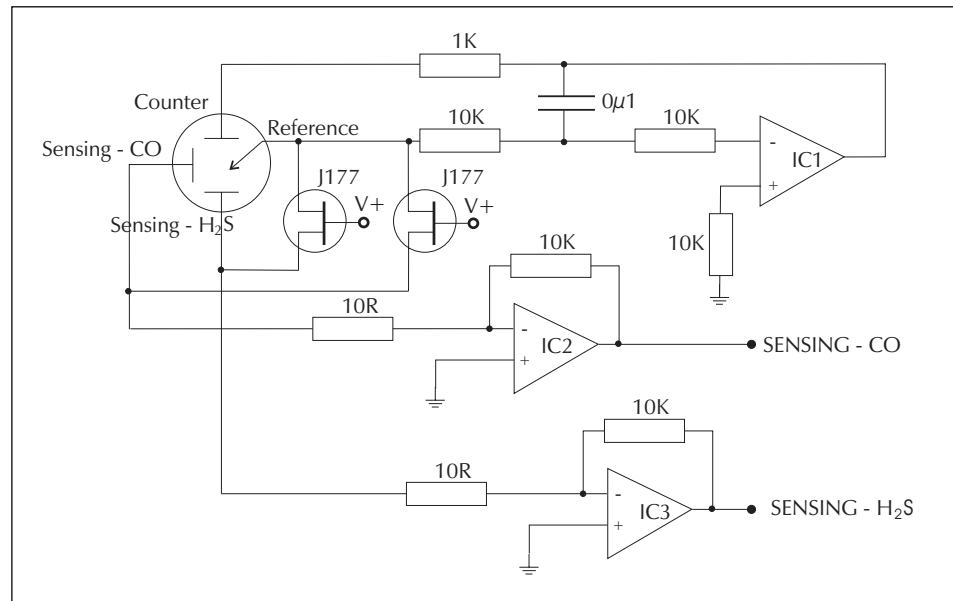

**Important Note**

The 4COSH circuit acts in the same way as those recommended for three electrode CiTiceLs, except there is an additional *sensing* electrode output. However the same considerations apply as when operating three electrode sensors, so it is important when considering these circuits to read the preceding section that deals with these.



---

## Operation

---

For correct operation, CiTiceLs require a small supply of oxygen to the *Counter* and *Reference* electrodes. This is usually provided in the sample stream, by air diffusing to the front of the sensor, or by diffusion through the sides of the sensor (a few thousand ppm is normally sufficient). Continuous exposure to an anaerobic sample gas may cause the sensor to malfunction in spite of the oxygen access paths. The sensor must not therefore be completely potted with resin or totally immersed in an anaerobic gas mixture.

---

## Start Up

---

### 1) Standard Operation CiTiceLs

---

To maintain a sensor in a 'ready to work' condition, most CiTiceLs (other than two electrode sensors) are supplied with a shorting link across the *Sensing* and *Reference* terminals. This must remain in place during storage, and only be removed when the sensor is ready to be used. Once in use, a sensor will require a long start up time if the electrodes are not resorted when the instrument is switched off. In the recommended circuit (see page TOX8), this is achieved by a shorting J-FET, which keeps the electrodes shorted when the circuit is unpowered.

### 2) Biased Operation CiTiceLs

---

Nitric Oxide, Ammonia, and Ethylene Oxide CiTiceLs are supplied without this shorting link. The 'biased' mode of operation required for these sensors has the electrodes at different potentials. As shorting can cause permanent damage, these CiTiceLs must be stored with the electrodes unshorted.

Applying bias potential to a new CiTiceL will produce a large, rapidly decreasing baseline which is sufficiently stable after several hours for measurements to be made (two to three hours for ammonia, ethylene oxide, or nitric oxide sensors, 24 hours or longer for hydrogen chloride). The baseline will continue to stabilise slowly during the following three weeks, after which time it should be fully settled.

It is strongly recommended that bias voltages be maintained at all times, even when an instrument is switched off. **If the bias potential is not maintained, very long start up times will result when the instrument is switched on.**

---

## Sampling Systems

---

One of the major considerations in designing a sampling system is ensuring the active gas component of a gas stream does not adsorb on to the surfaces of the materials used in the system. This will deplete the concentration of gas, until the material is saturated. Gases such as CO, H<sub>2</sub> and NO do not usually show any problems with surface adsorption. However adsorption problems do affect other gases, becoming increasingly significant in the order:

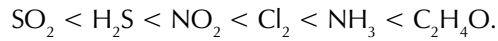

The effect can be minimized by ensuring materials with low absorption properties are used for surfaces which come into contact with the sample, along with high flow rates and short gas lines. Fluoropolymers such as Polytetrafluoroethylene (PTFE), Trifluorinated-ethylene (TFE) and Fluorinated Ethylene Propylene (FEP) have very low gas absorption properties and are suitable for use in gas handling systems. Stainless steel 316 and silicone rubber can be used as an alternative to plastic materials, but they do show absorption of  $\text{Cl}_2$  and  $\text{H}_2\text{S}$ . Polyester is favoured for gases other than  $\text{NO}_2$ .

Once adsorbed, gases will desorb back into the gas stream when the system is purged with a clean gas. This will then be detected by the sensor until all surface adsorbed gas is removed.

## Calibration

For maximum accuracy, CiTiceLs should be calibrated using a gas mixture in the range where most measurements are to be made. Where this is not possible, a mixture towards the top of the CiTiceL range should be chosen. Calibration gases exceeding the range of the CiTiceL must not be used as this may not provide an accurate calibration. The table below gives gas concentrations and flow rates appropriate for calibrating each CiTiceL, providing optimum performance with the minimum of gas hazard.

As calibration normally involves exposing the sensing face of the CiTiceL to gas for a relatively short period, a calibration gas need not contain oxygen - sufficient is supplied from ambient air, for a limited time, through the side access paths. In most cases, a five minute exposure time is sufficient to achieve a stable calibration signal. Depending on the equipment used, however,  $\text{H}_2\text{S}$ ,  $\text{Cl}_2$ ,  $\text{NO}_2$ ,  $\text{NH}_3$ , and  $\text{C}_2\text{H}_4\text{O}$  CiTiceLs may need a longer exposure time due to surface adsorption.

<b>Gas</b>	<b>Gas Concentration</b>	<b>Minimum Flow Rate</b>
<b>Carbon monoxide</b> .....	200ppm .....	150mls/min
<b>Hydrogen sulphide</b> .....	20ppm .....	250mls/min
<b>Sulphur dioxide</b> .....	20ppm .....	400mls/min
<b>Nitric oxide</b> .....	20ppm .....	250mls/min
<b>Nitrogen dioxide</b> .....	10ppm .....	400mls/min
<b>Chlorine</b> .....	10ppm .....	1000mls/min
<b>Hydrogen</b> .....	10ppm .....	1000mls/min
<b>Hydrogen cyanide</b> .....	10ppm .....	400mls/min
<b>Ammonia</b> .....	25ppm .....	250mls/min
<b>Ethylene oxide</b> .....	20ppm .....	1000mls/min
<b>Hydrides</b> .....	20ppm .....	1000mls/min



## Cross Sensitivity Data

### Cross-Sensitivity Notes

- Electrochemical CiTiceLs show no response to  $\text{CH}_4$ .
- With the exception of the 4AM, CiTiceLs show no response to  $\text{NH}_3$  or  $\text{CO}_2$ .
- 4AM CiTiceLs show a very small response to  $\text{CO}_2$ ; approx.  $-0.3\text{ppm}$  per  $\% \text{CO}_2$ .

CiTiceLs can generally be assumed to respond linearly to cross-interfering gases at TLV levels.

Part I includes tables of the *cross-sensitivity* of each CiTiceL to gases other than their target gas. These tables show the typical response of a sensor to a given concentration of test gas, normally around the TLV level. All values were obtained experimentally at City Technology.

Depending on the nature of the reaction each gas has with the sensor, the effect can either decrease the signal (negative cross-sensitivity) or increase the signal (positive cross-sensitivity). For safety concerns a negative cross-sensitivity may present more problems than a positive one, as this will serve to diminish the response to the target gas and so inhibit any alarm. In such cases it may be necessary to monitor both gases.

When using sensors with inboard filters, it is important to remember the life of the filter material is limited. This is very important for sensors designed for ambient monitoring, as the filters cannot be expected to remove cross-interfering gases at either continuous exposure levels or levels in excess of 100ppm. However for most ambient monitoring applications in which CiTiceLs are used, levels this high are not normally present.

When a sensor shows cross-sensitivity to a particular gas, whether or not this is a threat to accuracy in an application depends on the degree of accuracy required and the relative concentration of this gas relative to the target gas. For instance where  $\pm 10\%$  accuracy is needed, any gas likely to be present in a high enough concentration to cause a 10% signal should be monitored separately. An example follows:

***A 4CO CiTiceL is used in an application requiring measurement of carbon monoxide to an accuracy of  $\pm 10\%$ . In the same application it is possible that the sensor will also see small concentration of: 1)  $\text{H}_2\text{S}$ ; 2)  $\text{NO}_2$ .***

1) Likely concentration of  $\text{H}_2\text{S}$  expected to be  $< 1\text{ppm}$ .

**Cross-sensitivity to  $\text{H}_2\text{S}$ :** From the table in Part I, the response on a 4CO to 15ppm  $\text{H}_2\text{S}$  is approximately 38ppm CO.  
 $\therefore$  response to 1ppm  $\text{H}_2\text{S}$  will be approximately 2.5ppm.

Therefore  $\text{H}_2\text{S}$  will represent a threat to accuracy where CO concentration being measured is less than about 25ppm.

2) Likely concentration of  $\text{NO}_2$  expected to be  $< 2\text{ppm}$ .

**Cross-sensitivity to  $\text{NO}_2$ :** From the table in Part I, the response on a 4CO to 5ppm  $\text{NO}_2$  is approximately -3ppm CO  
 $\therefore$  response to 2ppm  $\text{NO}_2$  will be approximately -1.2ppm.

Hence  $\text{NO}_2$  is not a threat to accuracy where CO concentration being measured is higher than about 12ppm.

Although the tables provide a guide they do not dictate the behaviour of any particular sensor. Sensors may behave differently with changes in ambient conditions, and any batch may exhibit a range of 10-15%. Differences between batches will also be observed.



The table below shows % cross-sensitivity figures for 4-Series CiTiceLs tested with a range of potential cross-interfering gases.

N.B. With the exception of the 4AM, CiTiceLs show no response to either  $\text{NH}_3$  or  $\text{CO}_2$ . 4AM CiTiceLs show a very small response to  $\text{CO}_2$ , in the order of -0.3ppm per % $\text{CO}_2$ .

**Table 1: % Cross-sensitivity Data Summary for Toxic Gas CiTiceLs**

CiTiceL®	4CO	4CF	4COSH		4HS	4H	4S	4NT	4ND	4CL	4HYT	4HN	4AM	4ETO	4PH	4SL
			H <sub>2</sub> S electrode	CO electrode												
CO	100		~1	100	≤0.5	≤2	<1	0	≤-5	0	≤20		0	~40		~0.1
H <sub>2</sub> S	~250	<3	100	-20	100	100	<1		~8	~3	<20		~100			
SO <sub>2</sub>	~50	0	~2,	<1	~20	~10	100	0	0	0	0		~60		20	20
NO	<30	<10	<10	~15	<2	≤1	<1	100	0	0	~30		~20			
NO <sub>2</sub>	~60	≤20	~20	~25	~20	~20	~100	<30	100		0		0			
Cl <sub>2</sub>	0	0	~10	~5					-100	100	0		~50			
H <sub>2</sub>	<40	<40	<0.2	~30	~0.1	≤0.05					100		0		<0.1	
HCN											~30	100	~5			
HCl											0		0			
C <sub>2</sub> H <sub>4</sub>		<50									~80		0		~1.8	
N <sub>2</sub> O														~55		
C <sub>2</sub> H <sub>5</sub> OH		0												~20		
C <sub>6</sub> H <sub>5</sub> CH <sub>3</sub>														~10		
CH <sub>3</sub> CO <sub>2</sub> H <sub>5</sub>																
AsH <sub>3</sub>															80	90
SiH <sub>4</sub>															90	100
B <sub>2</sub> H <sub>6</sub>															35	40
GeH <sub>4</sub>															85	95
PH <sub>3</sub>																



## In-Board Filters

---

The designs of some 4-Series CiTiceLS include the addition of chemical, inboard filters to eliminate cross sensitivities to other gases which may be present. Each filter is designed to remove certain gases from a sample before it reaches the *Sensing* electrode, so eliminating particular cross-sensitivities.

As these inboard filters are built into a CiTiceL during assembly they do not alter the external dimensions of the CiTiceL.

The following 4-Series CiTiceLS have been developed with inboard filters:-

1. CO CiTiceL types **4CF**  
Filter material to remove trace environmental gases other than CO.
2. SO<sub>2</sub> CiTiceL type **4S**  
Filter material to remove cross sensitivity to H<sub>2</sub>S at TLV levels.

The life of the filter material is limited, but sufficient filter material is used to last the sensor life in normal sampling operations.

## Pressure Effects

---

CiTiceLS give a transient response when exposed to a sudden change in pressure in the presence of a measured gas. The peak signal decays in only a few seconds. This can be a particular problem when using sampling pumps, as they may introduce pressure fluctuations into the gas stream.

Pressure pulsations can be avoided by ensuring the sensor is positioned at the atmospheric end of the sample train. Alternatively a flow restriction placed upstream from the CiTiceL will also help to damp out pressure oscillations.

Another effective measure is to ensure that the back pressure downstream from the CiTiceL is effectively zero, so allowing an unrestricted flow of gas to ambient air. However it is important to prevent back diffusion from the ambient air diluting the gas stream and lowering the gas concentration being measured. Back diffusion can be reduced for example by the provision of an exhaust gas tube of 4mm internal diameter and 8mm length.



## Temperature Dependence

Both the span signal and the baseline (zero gas current) are affected by temperature.

### (a) Span

The output from a CiTiceL will vary only slightly with temperature. The temperature coefficient graphs in the specifications section show how the output of each sensor will change with gradual shifts in temperature. The graphs show the typical variation in span output with temperature for CiTiceLs calibrated at 20°C to a reading of 100% from a suitable test gas.

Example:

**Figure tox8**  
Typical CiTiceL  
temperature data graph

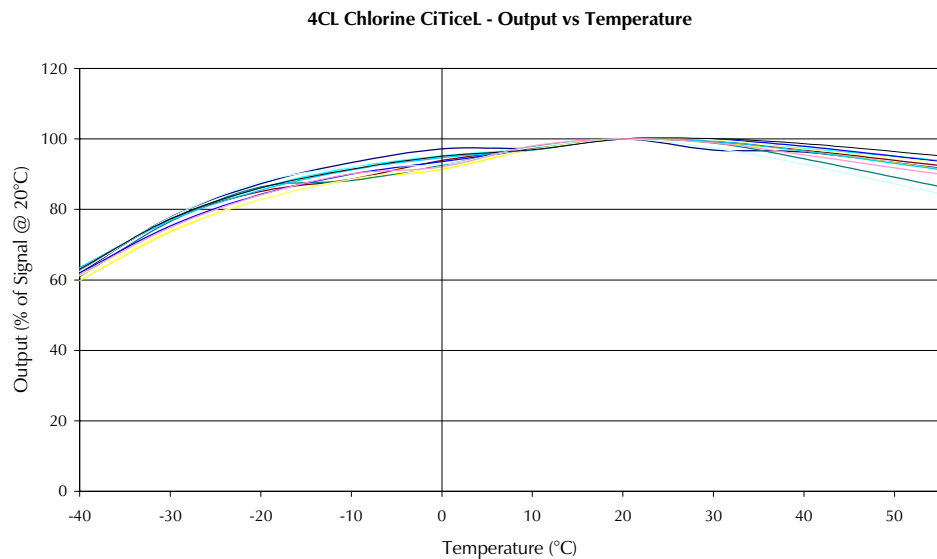

**Note:** For rapid changes in temperature a transient response will be seen, which dies away after about 20-30 seconds, before the output settles at the new level according to the graph data.

### (b) Baseline

The baseline signal follows an exponential relationship with temperature change. As a general guide, the baseline approximately doubles for every 10°C increase in temperature. The graphs in the specification section show how the baseline of each sensor type varies with temperature.



## Humidity Effects

Toxic Gas CiTiceLs are based on the use of aqueous electrolytes which, in conjunction with the porous diffusion barrier, permit water vapour to be absorbed into the electrolyte under conditions of high water vapour pressure, and allow the electrolyte to dry out at very low ambient water vapour pressure. Provided conditions are non-condensing the performance is relatively unaffected by humidity and will simply follow the change in concentration of the measured gas which results from changes in humidity. However when rapid changes in humidity occur, some sensors will show a transient response which should die away after about 20-30 seconds.

Continuous operation is possible between 15% and 90% RH over the full operating temperature range. Under these conditions the electrolyte will reach an equilibrium with the external water vapour pressure at a volume and concentration which does not affect the sensor's life or performance. Operation is also possible outside these conditions, but water transfer may occur and must be considered.

### High Humidity, High Temperature

Under continuous operation at high temperatures and 90-100% RH, water will slowly diffuse in. However water uptake is only harmful when the liquid volume increase exceeds the free space available. When this happens the sensor becomes prone to leakage - increasingly so as more and more water is taken up by the sensor. Removal from this humidity to a lower RH before leakage occurs will gradually restore the sensor to its original condition and no permanent harm will result from this exposure.

If a sensor shows signs of being affected by condensation, drying it with a soft tissue will restore normal operation. Under no circumstances should sensors be heated above 40°C to dry them out.

### Low Humidity, High Temperature

Similarly in continuous operation at 0-15% RH water will diffuse out. This will only be a problem when the volume of electrolyte has decreased by more than 40%, at which point the sensor gas sensitivity will be affected and the housing and seals may be attacked by the very concentrated electrolyte. Provided a sensor is not left in this condition long enough for such a reduction in the electrolyte to take place, it can be restored by exposure to a RH above 15%. At this level water ingress will begin to restore the water balance.

The rate at which water transfer occurs depends on the ambient temperature and relative humidity at the sensor. It also depends on the electrolyte and capillary hole size, both of which vary from one type of CiTiceL to another. In general, low sensitivity CiTiceLs will have slower water transfer rates and can be used for longer periods of time, whereas high sensitivity CiTiceLs (e.g. 4ND) will have higher water transfer rates, and should be operated for shorter periods of time in these conditions.